



**DUNCAN**  
AVIATION

# 2008/09 FALCON 2000EX EASY

SN 171 | N449SA



# 2008/09 FALCON 2000EX EASy SN 171 | N449SA

## HIGHLIGHTS

ONE U.S. FORTUNE 100 CORPORATE OWNER/OPERATOR SINCE NEW.  
EXCELLENT MAINTENANCE HISTORY. NO STORIES.

## AIRFRAME

Total Time: 8,253.9

Landings: 3,605

*Entered into service May 2009*

## ENGINE 1 2

Description: Pratt & Whitney PW308C

Program: ESP Gold

Total Time: 8,074.4 7,566.5

Cycles: 3,535 3,315

## APU

Total Time: 2,022

Cycles: 3,208

## MAINTENANCE

2C Inspection complied with 22 March 2021.

Landing Gear Overhaul complied with 22 March 2021.

Service Center Maintained.



**CONTACT:**  
Rene Cardona | +1 402.432.8220 | [Rene.Cardona@DuncanAviation.com](mailto:Rene.Cardona@DuncanAviation.com)  
[www.DuncanAviation.aero/aircraftsales](http://www.DuncanAviation.aero/aircraftsales)

Specifications, description, and photos are for informational purposes and are subject to verification by purchaser's inspection. Aircraft is subject to prior sale or withdrawal from market. Verification of aircraft equipment, times and aircraft condition is the sole responsibility of the purchaser.

# 2008/09 FALCON 2000EX EASy SN 171 | N449SA

## AVIONICS

### Honeywell HAPP

Avionics Package	Honeywell EPIC EASy II (Cert. 4)
IRF (Inertial Reference System)	Honeywell Third Micro IRF
VHF COMM (Very High Frequency Communication)	Honeywell Third VHF Voice and Flight Deck Data Link Comm
CMU (Communications Management Unit)	AFIS/SATAFIS Flight Deck Data Link Capability
SATCOM (Satellite Communication)	Yes
COMM/NAV COMPLIANCE	CPDLC with FANS-1/A+
HUD (Heads Up Display)	Rockwell Collins HGS-2850
FDR (Flight Data Recorder)	88 Parameter DFDR
CMS (Cabin Management System)	Collins Falcon Cabin Management System (FCMS) <i>Standard Definition with Collins Touchpads</i>
FMS (Flight Management System)	(3) Collins FMS 6100 with Cat II Autopilot
RADALT (Radar Altimeter)	(1) Radar Altimeter
CONNECTIVITY	Gogo AVANCE L5 <i>3-Year "SmartShield" Protection Plan</i>
WXRAD (Weather Radar)	XM NEXRAD

## ADDITIONAL FEATURES

Synthetic Vision
Honeywell SmartRunway RAAS
Pratt & Whitney Wireless Parameter Downloads with Data Transfer Unit (DTU) cable mod
Winslow Life Rafts with Beacons



**CONTACT:**  
Rene Cardona | +1 402.432.8220 | [Rene.Cardona@DuncanAviation.com](mailto:Rene.Cardona@DuncanAviation.com)  
[www.DuncanAviation.aero/aircraftsales](http://www.DuncanAviation.aero/aircraftsales)

Specifications, description, and photos are for informational purposes and are subject to verification by purchaser's inspection. Aircraft is subject to prior sale or withdrawal from market. Verification of aircraft equipment, times and aircraft condition is the sole responsibility of the purchaser.

# 2008/09 FALCON 2000EX EASY SN 171 | N449SA

## INTERIOR

- Complete interior refurbishment (November 2017)
- Eight-passenger seating configuration
- Reclining leather seats with footrests
- Warm sand leather, taupe carpet, cream headliner, textured ivory sidewalls
- High-gloss burl wood veneer with satin nickel accents
- Third flight deck seat with storage drawer and hangar bar
- Third crew member oxygen mask
- LH closet with horizontal manual storage
- 115VAC 60Hz 2000VA inverter with (7) outlets
- GoGo Biz® AVANCE L5 Wi-Fi connectivity

## GALLEY

- Pocket sliding door
- Auxiliary working surface
- High-temperature oven with digital controller
- Microwave oven
- Coffee brewer with two (2) carafes
- Ice and cold storage drawer
- Pop-out work surface

## EXTERIOR

**BASE:** Overall Matterhorn White

**STRIPES:** Dark Blue, Shadow Gloss, and Gloss Star Silver

- Exterior paint completed August 2016 (ceramic treated)
- Polished leading edges, inlet rings, and APU
- LED landing and taxi lights



**CONTACT:**

Rene Cardona | +1 402.432.8220 | [Rene.Cardona@DuncanAviation.com](mailto:Rene.Cardona@DuncanAviation.com)

[www.DuncanAviation.aero/aircraftsales](http://www.DuncanAviation.aero/aircraftsales)

Specifications, description, and photos are for informational purposes and are subject to verification by purchaser's inspection. Aircraft is subject to prior sale or withdrawal from market. Verification of aircraft equipment, times and aircraft condition is the sole responsibility of the purchaser.

# 2008/09 FALCON 2000EX EASy SN 171 | N449SA

## FLOOR PLAN

8 Passengers (Forward and Aft Club Configuration)

Jump Seat

Forward Galley

Aft Lavatory

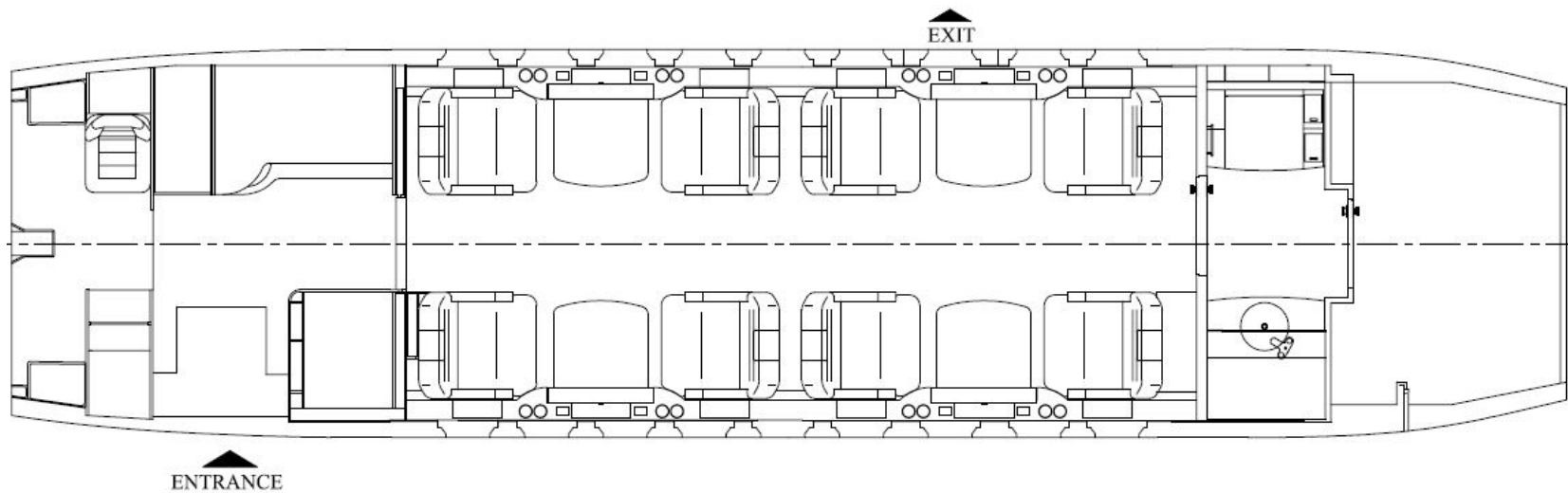

**CONTACT:**  
Rene Cardona | +1 402.432.8220 | [Rene.Cardona@DuncanAviation.com](mailto:Rene.Cardona@DuncanAviation.com)  
[www.DuncanAviation.aero/aircraftsales](http://www.DuncanAviation.aero/aircraftsales)

Specifications, description, and photos are for informational purposes and are subject to verification by purchaser's inspection. Aircraft is subject to prior sale or withdrawal from market. Verification of aircraft equipment, times and aircraft condition is the sole responsibility of the purchaser.

# 2008/09 FALCON 2000EX EASy SN 171 | N449SA

## PERFORMANCE & SPECIFICATIONS

(Source: Conklin & de Decker)

### SPEED

Normal Cruise: 459 kts  
Long-Range Cruise: 426 kts  
Max Cruise: 482 kts

### RANGE

#### Long-Range Cruise

Range: 4,082 nm  
Average Speed: 426 kts  
Endurance: 10 hrs  
Passengers: 4 people

#### Maximum Cruise

Range: 3,845 nm  
Average Speed: 445 kts  
Endurance: 9 hrs  
Passengers: 4 people

Seats Full: 3,878 nm  
Ferry Range: 4,045 nm



**CONTACT:**  
Rene Cardona | +1 402.432.8220 | [Rene.Cardona@DuncanAviation.com](mailto:Rene.Cardona@DuncanAviation.com)  
[www.DuncanAviation.aero/aircraftsales](http://www.DuncanAviation.aero/aircraftsales)

Specifications, description, and photos are for informational purposes and are subject to verification by purchaser's inspection. Aircraft is subject to prior sale or withdrawal from market. Verification of aircraft equipment, times and aircraft condition is the sole responsibility of the purchaser.

# 2008/09 FALCON 2000EX EASy SN 171 | N449SA

## PERFORMANCE & SPECIFICATIONS CONTINUED

(Source: Conklin & de Decker)

### INTERIOR

Total Cabin Volume: 1,028 cu ft  
Total Baggage Volume: 131 cu ft  
Cabin Width: 7.7 ft  
Cabin Length: 31.2 ft  
Cabin Height: 6.2 ft

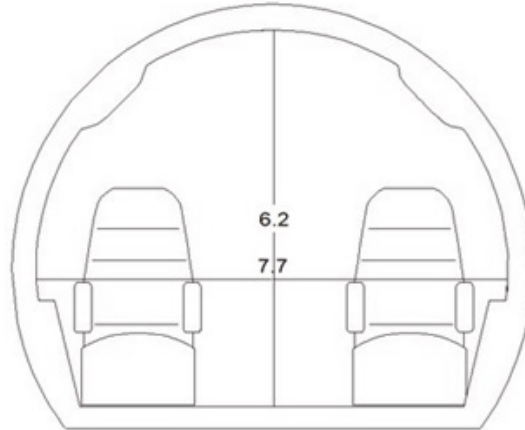

### CLIMB AND ALTITUDE

Rate of Climb: 4,375 ft/min  
Max Cert. Altitude: 47,000 ft  
Initial Cruise Altitude: 43,000 ft  
Time to Cruise Altitude: 20 min  
Service Ceiling: 43,000 ft

### EXTERIOR

Wingspan: 66.4 ft  
Fuselage: 66.3 ft

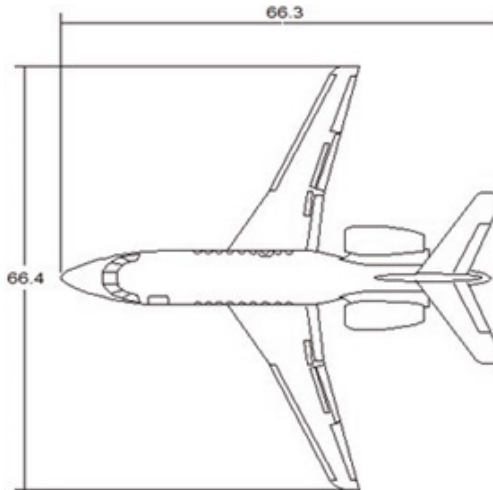

### WEIGHT/PAYLOAD

Ramp Weight: 42,400 lb  
Max Gross Takeoff Weight: 42,200 lb  
Max Landing: 39,300 lb  
Zero Fuel: 29,700 lb  
Basic Operating: 23,190 lb  
Useful Load: 19,210 lb  
Usable Fuel: 16,660 lb

### With Max Payload

Max Gross Takeoff Weight: 42,200 lb  
Range at Max Payload: 3,057 nm



**CONTACT:**  
Rene Cardona | +1 402.432.8220 | [Rene.Cardona@DuncanAviation.com](mailto:Rene.Cardona@DuncanAviation.com)  
[www.DuncanAviation.aero/aircraftsales](http://www.DuncanAviation.aero/aircraftsales)

Specifications, description, and photos are for informational purposes and are subject to verification by purchaser's inspection. Aircraft is subject to prior sale or withdrawal from market. Verification of aircraft equipment, times and aircraft condition is the sole responsibility of the purchaser.

# 2008/09 FALCON 2000EX EASy SN 171 | N449SA



CONTACT:

Rene Cardona | +1 402.432.8220 | [Rene.Cardona@DuncanAviation.com](mailto:Rene.Cardona@DuncanAviation.com)

[www.DuncanAviation.aero/aircraftsales](http://www.DuncanAviation.aero/aircraftsales)

Specifications, description, and photos are for informational purposes and are subject to verification by purchaser's inspection. Aircraft is subject to prior sale or withdrawal from market. Verification of aircraft equipment, times and aircraft condition is the sole responsibility of the purchaser.



# 2008/09 FALCON 2000EX EASy SN 171 | N449SA



**CONTACT:**  
Rene Cardona | +1 402.432.8220 | [Rene.Cardona@DuncanAviation.com](mailto:Rene.Cardona@DuncanAviation.com)  
[www.DuncanAviation.aero/aircraftsales](http://www.DuncanAviation.aero/aircraftsales)

Specifications, description, and photos are for informational purposes and are subject to verification by purchaser's inspection. Aircraft is subject to prior sale or withdrawal from market. Verification of aircraft equipment, times and aircraft condition is the sole responsibility of the purchaser.

# 2008/09 FALCON 2000EX EASy SN 171 | N449SA



**CONTACT:**  
Rene Cardona | +1 402.432.8220 | [Rene.Cardona@DuncanAviation.com](mailto:Rene.Cardona@DuncanAviation.com)  
[www.DuncanAviation.aero/aircraftsales](http://www.DuncanAviation.aero/aircraftsales)

Specifications, description, and photos are for informational purposes and are subject to verification by purchaser's inspection. Aircraft is subject to prior sale or withdrawal from market. Verification of aircraft equipment, times and aircraft condition is the sole responsibility of the purchaser.

# 2008/09 FALCON 2000EX EASy SN 171 | N449SA



**CONTACT:**  
Rene Cardona | +1 402.432.8220 | [Rene.Cardona@DuncanAviation.com](mailto:Rene.Cardona@DuncanAviation.com)  
[www.DuncanAviation.aero/aircraftsales](http://www.DuncanAviation.aero/aircraftsales)

Specifications, description, and photos are for informational purposes and are subject to verification by purchaser's inspection. Aircraft is subject to prior sale or withdrawal from market. Verification of aircraft equipment, times and aircraft condition is the sole responsibility of the purchaser.

# 2008/09 FALCON 2000EX EASy SN 171 | N449SA



**CONTACT:**  
Rene Cardona | +1 402.432.8220 | [Rene.Cardona@DuncanAviation.com](mailto:Rene.Cardona@DuncanAviation.com)  
[www.DuncanAviation.aero/aircraftsales](http://www.DuncanAviation.aero/aircraftsales)

Specifications, description, and photos are for informational purposes and are subject to verification by purchaser's inspection. Aircraft is subject to prior sale or withdrawal from market. Verification of aircraft equipment, times and aircraft condition is the sole responsibility of the purchaser.

# 2008/09 FALCON 2000EX EASy SN 171 | N449SA



**CONTACT:**  
Rene Cardona | +1 402.432.8220 | [Rene.Cardona@DuncanAviation.com](mailto:Rene.Cardona@DuncanAviation.com)  
[www.DuncanAviation.aero/aircraftsales](http://www.DuncanAviation.aero/aircraftsales)

Specifications, description, and photos are for informational purposes and are subject to verification by purchaser's inspection. Aircraft is subject to prior sale or withdrawal from market. Verification of aircraft equipment, times and aircraft condition is the sole responsibility of the purchaser.

# 2008/09 FALCON 2000EX EASy SN 171 | N449SA



**CONTACT:**  
Rene Cardona | +1 402.432.8220 | [Rene.Cardona@DuncanAviation.com](mailto:Rene.Cardona@DuncanAviation.com)  
[www.DuncanAviation.aero/aircraftsales](http://www.DuncanAviation.aero/aircraftsales)

Specifications, description, and photos are for informational purposes and are subject to verification by purchaser's inspection. Aircraft is subject to prior sale or withdrawal from market. Verification of aircraft equipment, times and aircraft condition is the sole responsibility of the purchaser.

# 2008/09 FALCON 2000EX EASy SN 171 | N449SA



**CONTACT:**  
Rene Cardona | +1 402.432.8220 | [Rene.Cardona@DuncanAviation.com](mailto:Rene.Cardona@DuncanAviation.com)  
[www.DuncanAviation.aero/aircraftsales](http://www.DuncanAviation.aero/aircraftsales)

Specifications, description, and photos are for informational purposes and are subject to verification by purchaser's inspection. Aircraft is subject to prior sale or withdrawal from market. Verification of aircraft equipment, times and aircraft condition is the sole responsibility of the purchaser.

# 2008/09 FALCON 2000EX EASy SN 171 | N449SA



**CONTACT:**  
Rene Cardona | +1 402.432.8220 | [Rene.Cardona@DuncanAviation.com](mailto:Rene.Cardona@DuncanAviation.com)  
[www.DuncanAviation.aero/aircraftsales](http://www.DuncanAviation.aero/aircraftsales)

Specifications, description, and photos are for informational purposes and are subject to verification by purchaser's inspection. Aircraft is subject to prior sale or withdrawal from market. Verification of aircraft equipment, times and aircraft condition is the sole responsibility of the purchaser.



# 2008/09 FALCON 2000EX EASy SN 171 | N449SA



**CONTACT:**  
Rene Cardona | +1 402.432.8220 | [Rene.Cardona@DuncanAviation.com](mailto:Rene.Cardona@DuncanAviation.com)  
[www.DuncanAviation.aero/aircraftsales](http://www.DuncanAviation.aero/aircraftsales)

Specifications, description, and photos are for informational purposes and are subject to verification by purchaser's inspection. Aircraft is subject to prior sale or withdrawal from market. Verification of aircraft equipment, times and aircraft condition is the sole responsibility of the purchaser.

# 2008/09 FALCON 2000EX EASy SN 171 | N449SA



**CONTACT:**  
Rene Cardona | +1 402.432.8220 | [Rene.Cardona@DuncanAviation.com](mailto:Rene.Cardona@DuncanAviation.com)  
[www.DuncanAviation.aero/aircraftsales](http://www.DuncanAviation.aero/aircraftsales)

Specifications, description, and photos are for informational purposes and are subject to verification by purchaser's inspection. Aircraft is subject to prior sale or withdrawal from market. Verification of aircraft equipment, times and aircraft condition is the sole responsibility of the purchaser.

# 2008/09 FALCON 2000EX EASy SN 171 | N449SA



**CONTACT:**  
Rene Cardona | +1 402.432.8220 | [Rene.Cardona@DuncanAviation.com](mailto:Rene.Cardona@DuncanAviation.com)  
[www.DuncanAviation.aero/aircraftsales](http://www.DuncanAviation.aero/aircraftsales)

Specifications, description, and photos are for informational purposes and are subject to verification by purchaser's inspection. Aircraft is subject to prior sale or withdrawal from market. Verification of aircraft equipment, times and aircraft condition is the sole responsibility of the purchaser.

# 2008/09 FALCON 2000EX EASy SN 171 | N449SA



**CONTACT:**  
Rene Cardona | +1 402.432.8220 | [Rene.Cardona@DuncanAviation.com](mailto:Rene.Cardona@DuncanAviation.com)  
[www.DuncanAviation.aero/aircraftsales](http://www.DuncanAviation.aero/aircraftsales)

Specifications, description, and photos are for informational purposes and are subject to verification by purchaser's inspection. Aircraft is subject to prior sale or withdrawal from market. Verification of aircraft equipment, times and aircraft condition is the sole responsibility of the purchaser.

# 2008/09 FALCON 2000EX EASy SN 171 | N449SA



**CONTACT:**  
Rene Cardona | +1 402.432.8220 | [Rene.Cardona@DuncanAviation.com](mailto:Rene.Cardona@DuncanAviation.com)  
[www.DuncanAviation.aero/aircraftsales](http://www.DuncanAviation.aero/aircraftsales)

Specifications, description, and photos are for informational purposes and are subject to verification by purchaser's inspection. Aircraft is subject to prior sale or withdrawal from market. Verification of aircraft equipment, times and aircraft condition is the sole responsibility of the purchaser.

## **OUR COMMITMENT:**

To leverage the extensive experience and resources of Duncan Aviation for the benefit of business aircraft sales and acquisition clients worldwide. Put 67+ years, more than 2,900 team members worldwide, and the experience that comes with over 3,500 aircraft transactions to work for you.



**Rene Cardona**  
**Sr. Aircraft Sales & Acquisitions**  
**+1 402.432.8220**  
**[Rene.Cardona@DuncanAviation.com](mailto:Rene.Cardona@DuncanAviation.com)**

Rene Cardona has been working in aircraft sales since 1980. In 1988, he joined Duncan Aviation's Aircraft Sales and Acquisitions team. His brokerage experience, understanding of the intricacies present in the preowned aircraft market and desire to work hard for his clients have served him well in his extensive career. Rene is bilingual in Spanish and English making him instrumental to numerous international transactions and benefiting his clients by expanding their market.

Rene has earned recognition as a Certified Aircraft Sales Broker from the International Aircraft Dealers Association (IADA), a rigorous evaluation process accrediting Rene as a highly-skilled broker at the top of his vocation, possessing relevant industry knowledge and adhering to the IADA code of ethics.

